

**AB-QM, 2½" thru 4" (2nd Gen)
5" thru 10" Valve Size
Pressure Independent Control Valve**

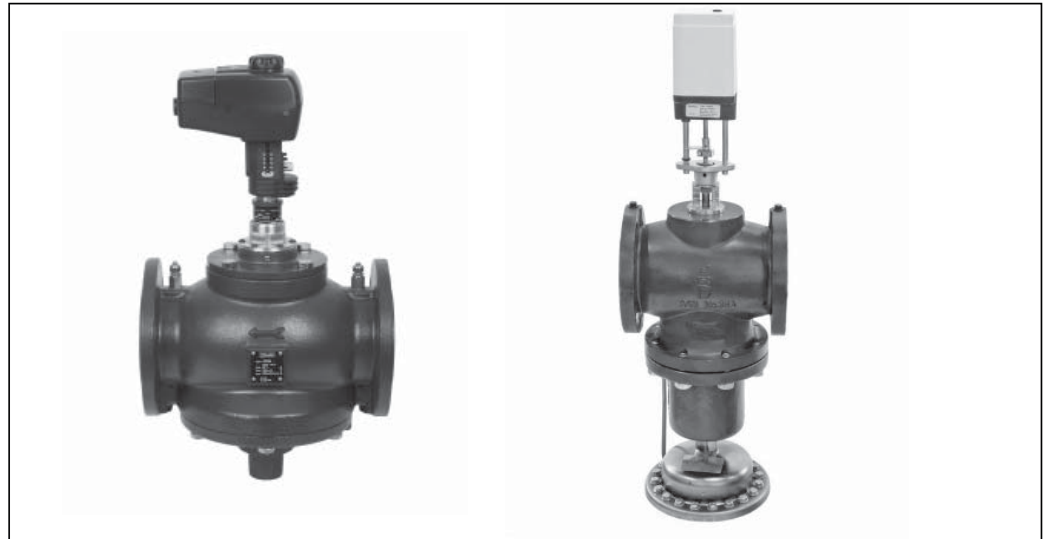

Features and Benefits:

The AB-QM temperature control valve provides pressure independent regulation of flow while also providing flow limiting system balance. The valve internally contains a unique differential pressure regulator which automatically adjusts to normal changes in system pressure from valves opening and closing or changing of pump speed. As a result of maintaining a constant pressure for the control valve, valve authority is maintained at 100%. This allows for precise interaction with the temperature controller and unparalleled system operation as indicated by assuring the highest possible coil log mean temperature difference (ΔT). The valve is easily set and adjusted to provide the precise flow required for each terminal unit. Design calculation and commissioning effort normally required for its control and balance valves are virtually eliminated because of the built in automatic pressure control regulator. A wide selection of actuators are available for the AB-QM providing further control features for the valve, making it an ideal selection for the simplest of two position control strategies to the precision required for modulating control and variable speed pump optimization.

Features:

- AB-QM maintains a stable flow through its range of operation unaffected by changes in system differential pressure
- 100% valve authority allows lower pump head than traditional valves and reduces energy consumption which increases ΔT
- Three required valve functions; control, balance and flow limitation in one compact valve design
- Flow parameter is the only consideration, reducing valve selection engineering
- Constant flow regulation limitation

- through independent pressure balancing
- User adjustable flow setting for maximum flow limitation
- Maintains linear characteristic of flow when installed with a Danfoss proportional actuator. Actuator options with equal percentage flow characteristics.

Benefits:

- Flow will always match the load
- Eliminate coil over flows
- Installation of the AB-QM reduces time and materials
- Simple flow setting procedure; reduced time involved for field commissioning
- Valve allows maximum coil and system differential temperature drops for optimum efficiency
- Operation costs reduced as much as 90% or more when properly applied with variable speed pumping
- "Plug and Play" for quick setup for balancing allowing immediate start up of unit
- Commissioning accomplished without use of specialized equipment
- Compact design allows installations in areas with limited space such as stand alone fan coils

**AB-QM, 2½" thru 4" (2nd Gen)
5" thru 10" Valve Size
Pressure Independent Control Valve**



Technical Data:

Nominal Diameter	2 ½"	3"	4"	5"	6"	8"	10"
Max flow (GPM)	85	120	165	395	640	830	1235
Connection	ANSI Flange (ANSI Standard B16.1)					ISO Flange & Gasket (ISO Flange EN 1092-2)	
Connection rating	ANSI Class 150					ANSI Class 125	
Control ΔP range	4 to 60 psi (0.28 to 4.0 bar)						
Control valve characteristic	Linear						
Control valve accuracy	± 5% of set point						
Max. close off differential pressure (across the valve)	90 psi (actuators to match)						
Max. Static (hold) Pressure	300 psi (20 bar)						
Medium temperature	15°F to 250°F (-10°C to 120°C)						
Allowable Fluid	Water and secondary refrigerant additives such as glycol						
Leakage	Class 4, metal to metal						

Ordering Information:

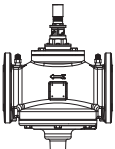
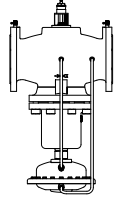
AB-QM	Code No.	Size	Max. Flow (GPM)
 With P/T Plugs	003Z0783	2½"	85
	003Z0784	3"	120
	003Z0785	4"	165
 With P/T Plugs	003Z0905	5"	395
	003Z0906	6"	640
	003Z0707	8"	830
	003Z0708	10"	1235

AB-QM Flanges and Gaskets

Code No.	Size	Description
D2576-16-200	8"	ISO Flat faced slip on flanges for AB-QM ISO flanged valves. Flange, PN16 rated. (2 required per valve body)
D2576-16-250	10"	
GASKET AB-QM 8"	8"	Accompanying gasket for selected flange size. (2 required per valve body)
GASKET AB-QM 10"	10"	

AB-QM Accessories

Code No.	Description
003Z0695	Brass handle for AB-QM 2½" thru 4"
003Z0696	Brass handle for AB-QM 5" thru 10"

**AB-QM, 2½" thru 4" (2nd Gen)
5" thru 10" Valve Size
Pressure Independent Control Valve**



**Electric Actuator
Selection Information:**

Refer to electric actuator data sheet for further information.

For Valve Sizes 2½" to 4"			Input Signal			Output Signal (0-10VDC)	Safety Function	
Style	Code No.	Power	On/Off	Floating	Modulating		Up	Down
AME435 QM	082H0171	24Vac			•	•		
AMV435	082H0162	24Vac		•		•		
AME25SU*	082H3041	24Vac		•	•	•	•	
AME25SD*	082H3038	24Vac		•	•	•		•

*Adapter required for 2nd gen valve. Part # 065Z0311

For Valve Sizes 5" to 10"			Input Signal			Output Signal (0-10VDC)
Style	Code No.	Power	On/Off	Floating	Modulating	
AME55QM	082H3078	24Vac		•	•	•
AME85QM	082G1453	24Vac		•	•	•

Available battery backup assembly for safety function, AM-PBU25, **082H7090**

Application:

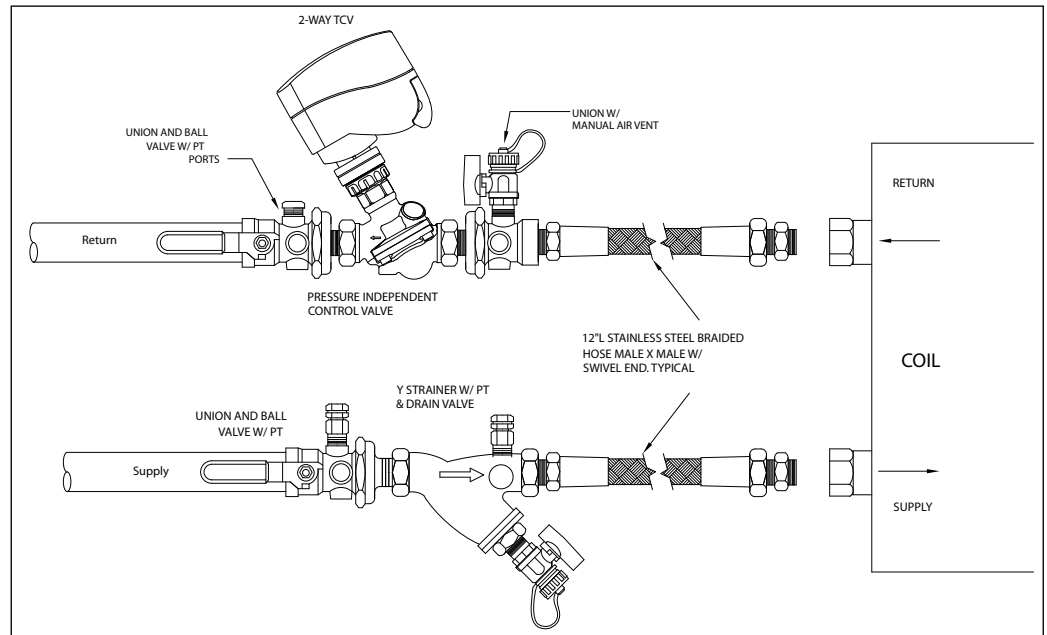

The AB-QM is a versatile device that can be used as an actuated or non-actuated balance valve / flow limiter. With an actuator mounted to the AB-QM valve, the assembly is a pressure independent control valve. Utilizing a proportioning controller, the AB-QM creates a robust and stable energy management sub system using only the required flow and energy to offset facility heat transfer gains and losses.

The integrated AB-QM differential pressure regulator virtually eliminates the problem of fluctuating pressures on control valve performance. The AB-QM regulator immediately reacts to all changes in

system pressure creating the stability to make the valve flow and control predictable and controllers and valves work as intended. Energy is saved taking advantage of the greatly reduced amount of flow required for heat transfer of full valve authority for an air handling unit (AHU), fan coil, etc. With the AB-QM the required design flow to the AHU is met, subsequently simplifying the balancing of the system. Air handling units react quickly to changes in the building load and simple proportional control will not accurately regulate these systems. Using control integral action to adjust for this requires skill and extra commissioning to properly match the required

**AB-QM, 2½" thru 4" (2nd Gen)
5" thru 10" Valve Size
Pressure Independent Control Valve**



Application (Con't):

setting to the applications, sometimes over several seasons of operation. The AB-QM differential pressure regulator acts as an extra sub-master controller and makes tuning the main controllers easier and less time consuming. Smaller building HVAC sub-systems such as fan coil units, or terminal unit heating coils and newer modern designs such as chilled beams or radiant cooling panels greatly benefit from AB-QM application even when applied with simple thermostatic operation. No pressure calculations are required, valve authority doesn't need to be calculated and no calculations have to be performed to pre-set a balancing valve. If

extra flow is determined to be required while tuning the installation, it's easy for the commissioning agent to reset the AB-QM for any flow up to the rated range of the valve. The HVAC units and controllers will benefit from greatly enhanced ability to control, with no overflow. AB-QM allows hydronic HVAC systems to achieve the green and sustainable performance envisioned by their designers and owners. Owners benefit in significant reductions in commissioning time, energy cost in operation from reduced flow and reduced complaints associated with improper temperatures within the building.

Valve Operation / Design:

Function:

The AB-QM combines aspects of both a differential pressure controller and a control valve into a single valve.

- P1 Available Pressure
- P2 Regulated inlet pressure to control valve
- P3 Exit pressure of valve

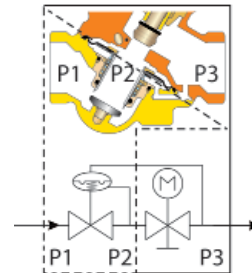

AB-QM 2½" - 4"

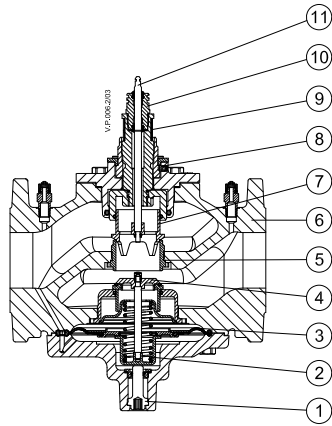

1. Shut off screw
2. Main spring
3. Membrane
4. DP cone
5. Seat
6. Valve body
7. Control valve cone
8. Locking screw
9. Scale
10. Stuffing box
11. Spindle

AB-QM 5" - 10"

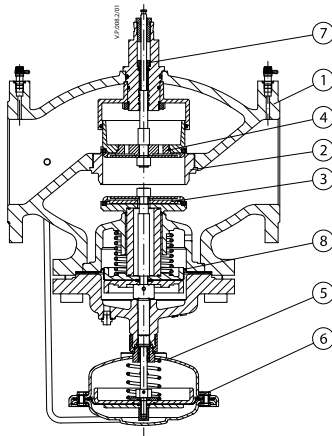

1. Valve body
2. Valve seat
3. DPC cone
4. Cv cone
5. Controller casting
6. Rolling diaphragm
7. Adjusting screw
8. Bellows for pressure relief on DPC cone

**AB-QM, 2½" thru 4" (2nd Gen)
5" thru 10" Valve Size
Pressure Independent Control Valve**



Differential Pressure Regulator:

Flow enters the valve through the differential pressure regulator, which maintains a constant pressure difference across the control valve orifice. As entering pressure increases or decreases in reaction to changes in flow and pump speed in the piping system, the regulator diaphragm is balanced with the force of the spring keeping a constant pressure difference (P2 - P3) between the water entering the temperature control valve and the leaving side of the valve. As a result the differential pressure across the control valve (P2 - P3) is at a constant level.

A nominal 5 psi differential is required from P1 to P3 for the valve and flow regulator operation. The regulator controls the range of system differential pressure to 60 psi (140 FOH). Under normal system operation such as in variable speed pumping, as system flow is reduced, controlled pump speed reduces the system differential pressure (head) of the pump. In constant speed pumping applications reductions in system flow may result in increased system differential pressure (head) of the pump.

Control Valve Flow Coefficient and Characteristic, Cv:

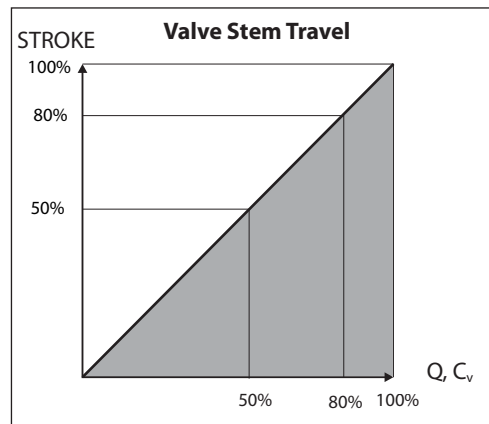

The linear characteristic of the valve allows for application flexibility. By adjusting the maximum valve stem travel is also adjusted. Even through this adjustment the control performance is not compromised. On - Off controls will cycle between full and no flow positions, and proportional control actuators upon reset will self calibrate to the new adjusted stem travel, and still utilize the entire input signal range. Maintaining a linear characteristic allows for the predictability required to characterize the control signal when needed in an application. Signal characterization is optimally done in the controller, but may be done through an available actuator which allows matching to the terminal unit characteristic.

Flow Adjustment:

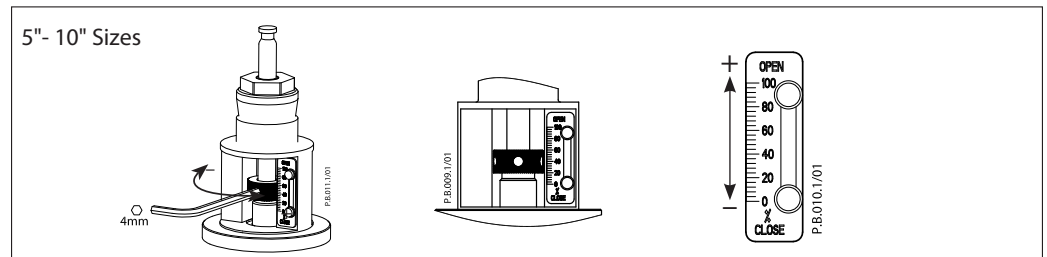
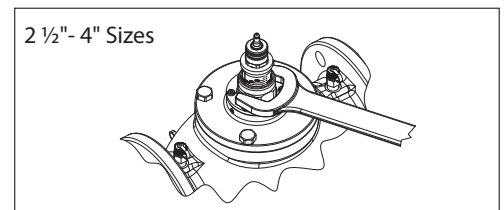
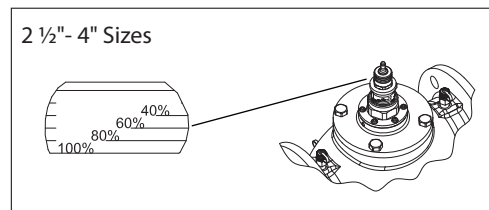

Example:

Required flow rate:
100 GPM

Selected valve size:
4" Maximum flow (Qmax)= 165 GPM
Therefore, 100/165 = 0.6 -> 60%

Set the valve to 60% to achieve 100GPM through the valve.

Danfoss recommends a presetting range from 20% to 100%. Factory presetting is 100%.

By turning the grey collar counter clockwise would increase while clockwise would decrease the flow. When valve is set to 80% or more the red line becomes visible.

**AB-QM, 2½" thru 4" (2nd Gen)
5" thru 10" Valve Size
Pressure Independent Control Valve**



Valve Authority:

Valve authority can be generally defined as a measure of the change in differential pressure across a control valve during operation. This value is calculated by dividing the pressure drop of the control valve (ΔP_{VALVE}) by the sum of the pressure drop of the control valve (ΔP_{VALVE}) and system (ΔP_{SYSTEM}) it serves e.g. the pipes, fittings, coil, and other devices that become part of the system.

$$A = \frac{\Delta P_{Valve}}{\Delta P_{Valve} + \Delta P_{System}}$$

The calculated result is expressed as a percent ratio, with 100% authority being an ideal scenario achieved in laboratory conditions. Within a lab, a constant differential pressure is maintained across the control valve and as a result an equal or linear relationship is achieved between the flow requirements and control valve's position. In reality in meeting the output requirements in a variable flow system the resulting reaction between the terminal and the control valve performance can be less than ideal. The dynamic variations (ΔP) within the entire system e.g. other actuating control valves, create fluctuations to the differential pressure across the control valve resulting in a lower valve authority percentage. The lower the valve authority, the worse the controllability is between the terminal and control valve resulting in inconsistent room temperature.

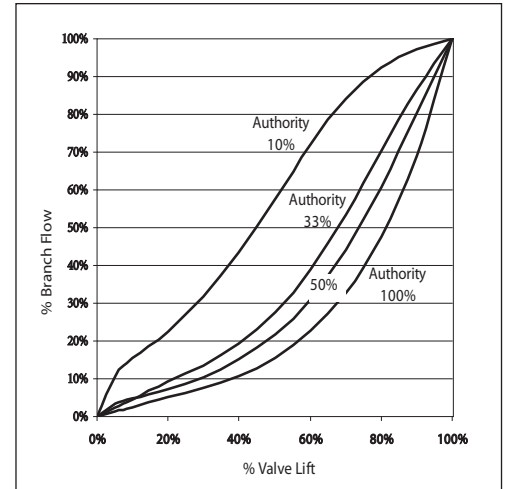

The interaction of ΔP_{SYSTEM} on the control valve can significantly hinder the control valve's effectiveness. The design of the AB-QM's internal differential pressure regulator address this by counteracting the inlet ΔP_{SYSTEM} fluctuations, and as a result a constant differential pressure across the control valve is achieved.

With a constant differential pressure across the inlet and outlet of the control valve portion of the AB-QM, a more ideal scenario is approached. The result is the AB-QM valve assembly operates at 100% valve authority.

Typical Specification:

Revised Construction Specifications Institute standard numbering is utilized. The Specifier is advised to coordinate product provisions with other speciality specification areas as more than one may apply. The model for this specification and suggested placement is based on the "Unified Facilities Guide Specifications" downloadable from the Whole Building Design Guide web site (www.wbdg.org) and found under the "Documents & References" specifications library. The WBDG web site is offered as an assistance to the building community by the National Institute of Building Sciences (NIBS) through funding support of several US government agencies.

SECTION 23 09 23

DIRECT DIGITAL CONTROL FOR HVAC AND OTHER LOCAL BUILDING SYSTEMS

PART 2 PRODUCTS

2.6 AUTOMATIC CONTROL VALVES

Valves shall have stainless-steel stems and stuffing boxes with extended necks to clear the piping insulation. Valves bodies shall meet ASME B16.34 or ASME B16.15 pressure and temperature class ratings based on the design operating temperature and 150 percent of the system design operating pressure.

Unless otherwise specified or shown, valve leakage shall meet FCI 70-2 Class IV leakage rating (0.01

percent of valve Kv). Unless otherwise specified or shown, valves shall be two way pressure independent globe-style bodies. Unless otherwise specified:

- a. bodies for valves 2 inches and smaller shall be brass or bronze, with union ends
- b. bodies for valves 2 to 3 inches shall be of brass, bronze or iron.
- c. bodies of valves 2½ inches and larger shall be provided with flanged-end connections
- d. valve and actuator combination shall be normally open or normally closed as shown

2.6.1 Two-Way Pressure Independent Globe Valves

Two-way modulating valves used for liquids. The valve shall be two way globe style with integrated differential pressure control regulator. Where indicated modulating proportional valve application shall utilize

**AB-QM, 2½" thru 4" (2nd Gen)
5" thru 10" Valve Size
Pressure Independent Control Valve**



**Typical Specification
(Con't):**

controller or actuator to match required control signal to complement controlled coil heat transfer characteristic for linear control, the valve shall:

- a. provide integrated pressure regulator; regulator to control pressure across control valve orifice
- b. provide regulator incorporating EPDM diaphragm, stainless steel spring and pressure control disc. Pressure control seat shall be brass construction with vulcanized EPDM
- c. provide counterbalance of supply pipe pressure to return pipe pressure across diaphragm to prevent diaphragm damage when control valve is closed
- d. provide user adjustable maximum flow within valve control range; Adjustment method shall indicate percentage of valve flow range and utilize spring locked method of adjustment
- e. regulate internal control valve differential pressure to provide 100% control valve authority
- f. shall have linear flow characteristic
- g. provide back seated globe design to allow service of packing under pressure without leakage
- h. provide entering to leaving (P1-P3) pressure control across valve ½" in size from 2.3PSI - 60PSI
- i. provide entering to leaving (P1-P3) pressure control across valves ½" - 1¼" in size from 5PSI - 60PSI
- j. provide entering to leaving (P1 - P3 pressure control across valves 1½" - 10" in size from 4PSI - 60PSI
- k. provide union connections
- l. utilize stainless steel internal trim with brass globe seat
- m. utilize threaded actuator connection
- n. flow requirements shall be sized to provide nominal body selection no more than one size smaller to corresponding nominal pipe connection
 - a. ½" bodies shall be utilized for ½" pipe and may be utilized for ¾" pipe connection and flow less than 5 GPM
 - b. ¾" bodies may be utilized for ¾" pipe and may be applied to 1" pipe connection with flow less than 7.5 GPM
 - c. 1" bodies may be utilized for 1" pip and may be applied to 1¼" pipe connection with flow less than 12 GPM
 - d. 1¼"bodies may be utilized for 1¼" and may be applied to 1½" pipe connection with flow less than 17.5 GPM
 - e. 1½" bodies may be utilized for 1½" pipe and may be applied to 2" pipe connection with flows less than 33 GPM
 - f. flows less than 55 GPM may use 2" bodies
 - g. flows less than 85 GPM may use 2½" bodies
 - h. flows less than 120 GPM may use 3" bodies
 - i. flows less than 165 GPM may use 4" bodies
 - j. flows less than 395 GPM may use 5"bodies
 - k. flows less than 640 GPM may use 6" bodies

- l. flows less than 830 GPM may use 8" bodies
- m. flows less than 1235 GPM may use 10" bodies

2.6.2 Duct-Coil and Terminal-Unit-Coil; Hot and Chilled Water Systems

Control valves utilized for controlled flows shall be proportionally modulated. Control valve shall be integrated into coil assembly package. Coil assembly package shall conform to requirements of other common valves as specified in Section 23 05 15 Common Piping For HVAC. Coil assembly package shall:

- a. provide integrated ball valve and wye pattern strainer. Strainer shall be #20 mesh. Strainer valve shall provide pressure and temperature measurement port with integrated positive shutoff gland seal. Strainer valve shall have plugged ¼" female NPT accessory port. Strainer valve shall provide integrated ¼" ball drain valve with cap and common hose connection. Strainer valve shall provide integrated union connection and tailpiece. Strainer valve shall be provided to match flow requirements for connected control valve.
- b. provide union connection entering and leaving piping of coil. Union connection fitting shall include three accessory ¼" female NPT tapped ports for test and other HVAC devices. Provide pressure and temperature measurement ports with integrated positive shutoff gland seal in unions entering and leaving coil. Provide manual air vent in union leaving coil. Provide ¼" threaded plugs in all unused union ports. Provide union nut, tailpiece and o-ring seal, or appropriate connectors to flexible piping.
- c. provide ball shutoff valve with integrated union. Valve shall provide pressure and temperature measurement port with integrated positive shutoff gland seal. Valve shall have plugged ¼" female NPT accessory port. Provide union nut, tailpiece and o-ring seal, or appropriate connectors to flexible piping.
- d. provide flexible piping for connection to coil. Piping shall be configured such that unions are hard mounted to coil either directly or with elbows as appropriate to allow straight flexible connection without ninety degree change in direction. Flexible pipe shall be mounted between coil union and control valve or strainer valve.

**AB-QM, 2½" thru 4" (2nd Gen)
5" thru 10" Valve Size
Pressure Independent Control Valve**



Dimensions:

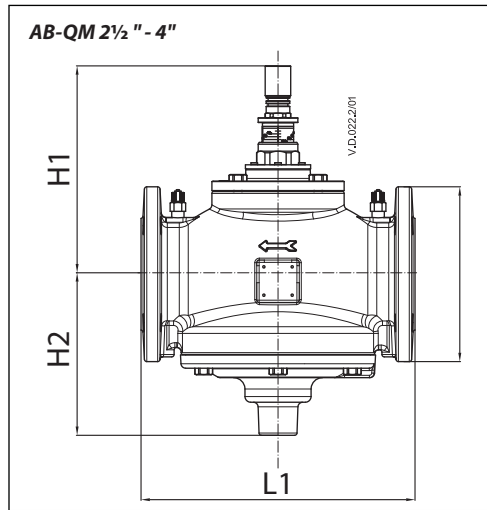

Contact With Water

Valve bodies	Grey cast iron A48 No.35A
Membranes / Bellows	EPDM
O-rings	EPDM
Springs	ASTM-631, ASTM-301
Cone (Pc)	C37710, ASTM-303
Seat (Pc)	ASTM-303
Cone (Cv)	C37710
Seat (Cv)	ASTM-303
Screw	Stainless Steel (A2)
Flat	NBR

Valve size	Dimensions, in (mm)			a (ANSI.B16.1)	Weight lb (kg)
	L1	H1	H2		
2½"	11.4 (290)	8.7 (220)	6.8 (172)	7.1 (180)	84 (38)
3"	12.2 (310)	8.9 (225)	7.0 (177)	7.5 (190)	99 (45)
4"	13.8 (350)	9.4 (240)	7.4 (187)	9.1 (230)	126 (57)

**AB-QM, 2½" thru 4" (2nd Gen)
5" thru 10" Valve Size
Pressure Independent Control Valve**



Dimensions (Con't):

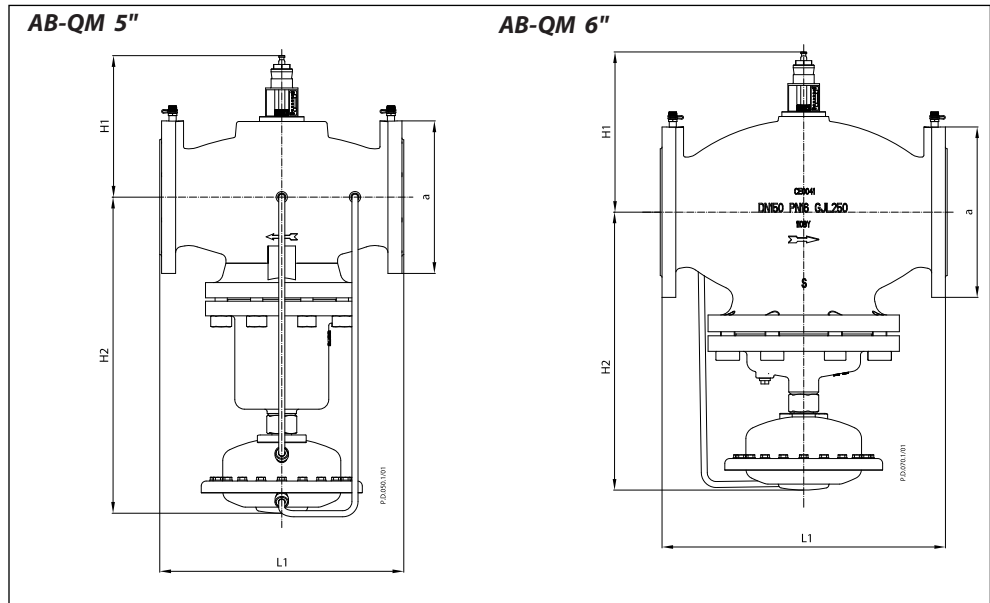

Contact With Water

Body	Grey cast iron A48 No. 35A
Membrane	W.Nr.1.4571; Stainless Steel
Diaphragm O-ring	EPDM
Springs	ASTM-316N
Cone (Pc)	ASTM-316L
Seat (Pc)	ASTM-420
Plug (Cv)	ASTM-316L
Seat (Cv)	ASTM-420
Screw	ASTM-1055
Flat Gasket	Non asbestos

Valve size	Dimensions, in (mm)			a (Flange)	Weight lb (kg)
	L1	H1	H2		
5"	12.5 (318)	9.1 (232)	20.4 (518)	10.0 (255)	188 (85)
6"	14.5 (368)	10.6 (268)	18.3 (465)	11.0 (280)	304 (138)

**AB-QM, 2½" thru 4" (2nd Gen)
5" thru 10" Valve Size
Pressure Independent Control Valve**



Dimensions (Con't):

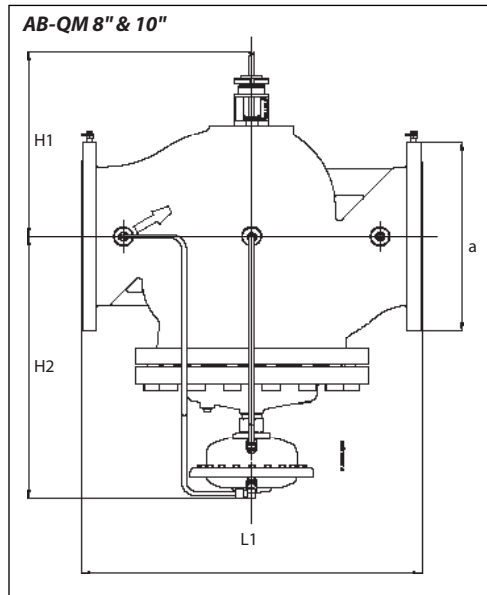

Contact With Water

Body	Ductile iron EN-GJL-250 (GG25)
Membrane	EPDM
Diaphragm O-ring	EPDM
Springs	W.Nr.4310; Stainless Steel
Cone (Pc)	W.Nr.1.4021; Stainless Steel
Seat (Pc)	W.Nr.1.4027; Stainless Steel
Cone (Cv)	W.Nr.1.4021; Stainless Steel
Seat (Cv)	W.Nr.1.4027; Stainless Steel
Screw	W.Nr.1.1181; Stainless Steel
Flat Gasket	Non asbestos

Valve size	Dimensions, in (mm)			a (Flange)	Weight lb (kg)
	L1	H1	H2		
8"	19.5 (495)	16.0 (406)	19.01 (483)	13.6 (345)	483 (219)
10"	24.5 (622)	15.63 (397)	21.00 (533)	15.94 (405)	754 (342)

Danfoss can accept no responsibility for possible errors in printed materials and reserves the right to alter its products without notice. All trademarks in this material are property of the respective companies. Danfoss and Danfoss logotype are trademarks of Danfoss A/S. All rights reserved.



Danfoss
Mississauga, ON / Baltimore, MD
Tel.: 1-866-676-8062
Fax: 905-285-2056
www.ABQMvalves.com